



LAYERZERO

POWER SYSTEMS, INC.

The Foundation Layer

LayerZero eSTS

600 A - 1600 A Static Transfer Switch



Product Brochure

The LayerZero eSTS Static Transfer Switch

Maximizes Power Reliability

eSTS Automatically Transfers Between Two or Three* Power Sources

Over the life of a data center there will be both planned and un-planned events affecting the reliability and uptime of your facility. A LayerZero Power Systems Static Transfer Switch (eSTS) will significantly help with maintaining high levels of both metrics. LayerZero’s eSTS continuously monitors the power quality, and if an event or equipment upstream of the static transfer switch jeopardizes the critical load, eSTS will transfer away from danger within the limits of the ITIC curve. If a fault occurs downstream, eSTS will not propagate the fault. Maintaining independence between sources is critical when maintaining a tolerant system topology.

LayerZero’s eSTS allows for concurrent maintenance to occur by providing the option to safely transfer loads from one protected source to another while maintaining the load. The ability to quickly switch between primary and alternate sources allows facilities to perform needed maintenance without putting the critical load at risk.

In many cases the static transfer switch is the last line of defense. For maximum reliability, the LayerZero eSTS is designed with robust internal redundancy and contains no single points of failure. LayerZero develops innovative products with close attention to detail, and applies the best practices used in critical industries to deliver the very best Static Transfer Switch available in the world.

*Optional

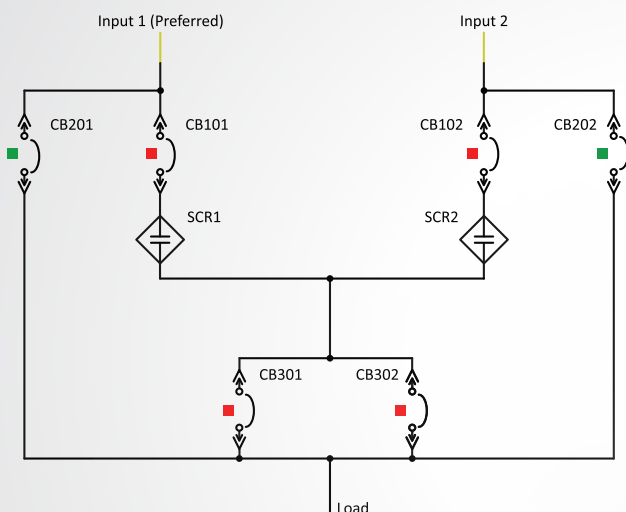

2-Source eSTS One Line Diagram



1000 A eSTS

eSTS Has Been Carefully Designed To Facilitate Maximum Operator Safety

eSTS is Designed for Safe Operation

For maximum operator safety, the LayerZero eSTS utilizes a sectionalized design, housing the power quality monitoring and SCRs in a cabinet adjacent to the circuit breakers and customer cable connections. The sectionalized compartment design of the eSTS allows the equipment to be safely operated and serviced. In normal operation of the eSTS, the inner dead-front doors remain closed. A mechanical interlock is built into the door, permitting safe operation of the bypass procedure by eliminating human error. A polycarbonate window allows for status LEDs in the control section to be safely viewed with the door closed. INSIGHT IR® cameras (optional) or IR Ports (standard) provide the ability to monitor the temperatures of critical connections with the doors safely closed.

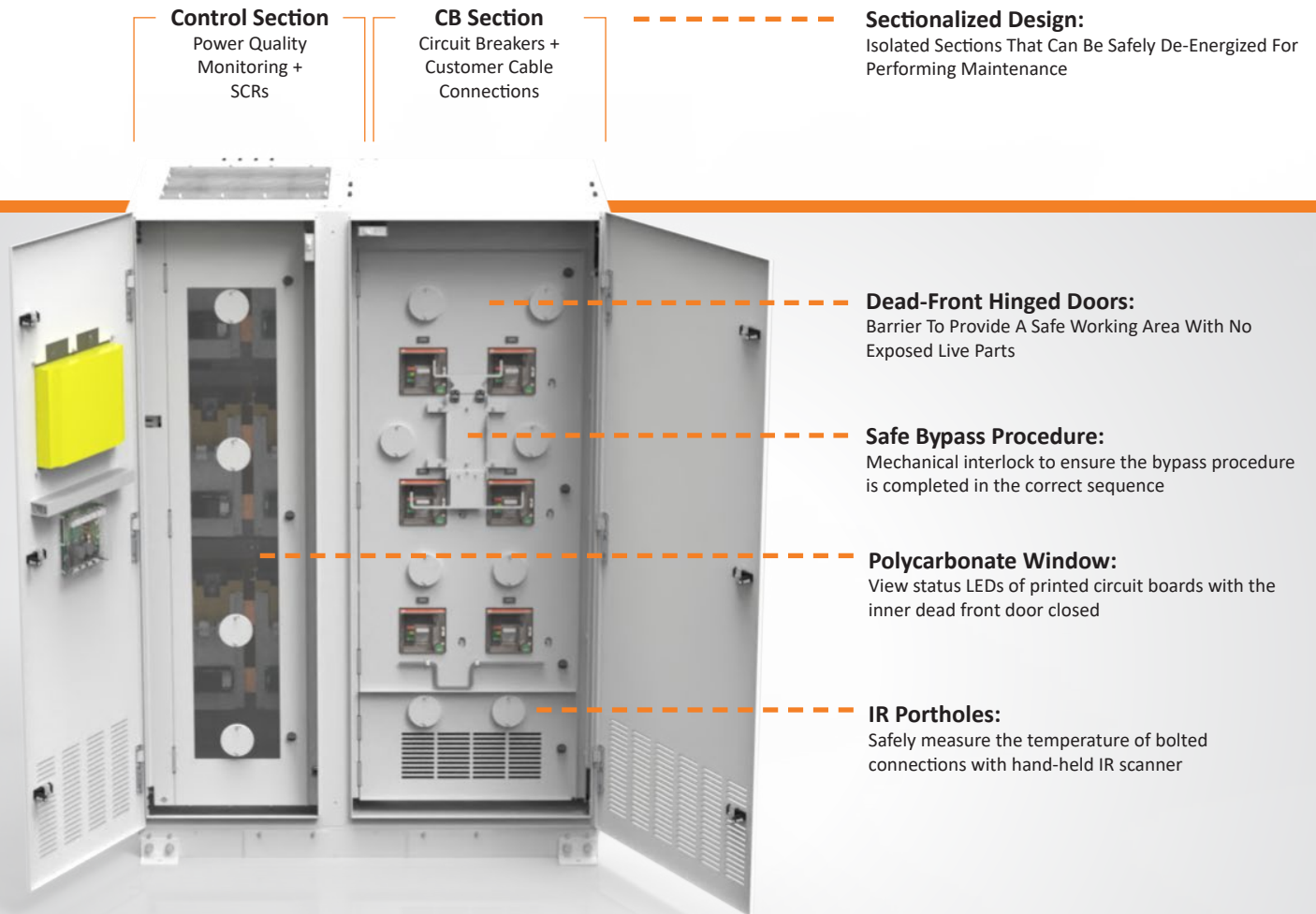

eSTS Provides Long-Term Reliability with Maintenance-Free Connections

LayerZero eSTS is Designed for True Front-Only Access

The eSTS has been designed to be accessible from the front-only, there is no need to ever access difficult-to-reach locations. Input/output terminals can be accessed from the front/bottom of the equipment. The buswork of LayerZero eSTS systems is epoxy coated for additional operator safety and connections are silver plated for reliability. Internal connections are permanently brazed and are maintenance-free.

Designed for Consistent Torque Throughout Product Life

To maximize product reliability and minimize maintenance, our bolted connections utilize machined cap screws and engineered disc springs. The result is a flat pressure vs deflection profile to ensure that all bolted connections maintain constant torque through the life of the product. These technologies have been well tested in disparate environments of wide temperature ranges to help ensure that, once connections have been tightened, they stay that way.

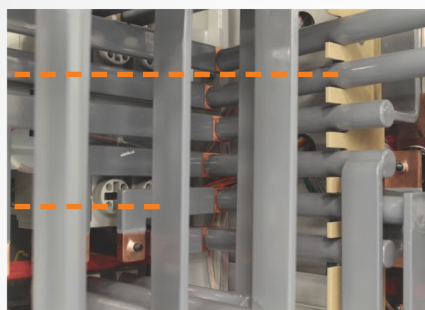

Brazed Connections:
Junctions are permanent and maintenance-free

Epoxy Coated Bus Bars:
Insulates buswork for safety and reliability

Buswork Behind Circuit Breakers

Silver Plated Customer Connections:
Silver provides excellent conductivity



eSTS is Equipped with Built-In Redundancy With No Single Point-Of-Failure

Designed with Fail-safe Topology For Maximum Reliability

The LayerZero eSTS Static Transfer Switch is designed with internal redundancy, every logical machine segment of the eSTS Static Transfer Switch is powered with triple redundant power supplies. To eliminate the risk of signal interference and to maximize system reliability, control communications utilize fiber optic signals.

LayerZero eSTS is equipped standard with Single Module Redundancy (SMR), a cost-effective topology that provides redundant power paths to mission-critical equipment. In SMR systems, sources each have built-in triple redundancy of processors, and every phase is controlled with a separate gate drive board. LayerZero Single Modular Redundant topology is unique that it the system is fail-safe, maintaining full switching functionality even if a critical board were to fail.

For applications where reliability simply cannot be compromised, eSTS offers Triple Modular Redundant (TMR) architecture, so that a failure of any component on any board will not compromise the critical load. With appropriate and timely service and maintenance an eSTS TMR system will maintain virtually 100% probability of mission success.

Internal Redundancy:

Dedicated power supplies and logic redundancy to maximize reliability

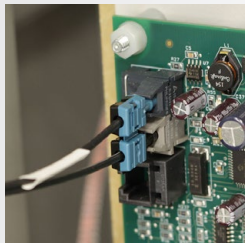

Optical Fiber Based Controls:

Eliminates Noise and Interference While Isolating Components from High Voltage



Innovative Technologies Designed for Maximum System Availability

Eliminates Human Error

Operator error during maintenance bypass has been known to be a reliability hazard. In order to minimize the possibility of operator error during equipment bypass operations, LayerZero provides:

1. Interlocked breakers
2. Mechanisms to ensure that a source cannot be bypassed without the STS on the correct source.
3. Safeguards to make certain that sources cannot be connected to each other inadvertently.
4. A voice-prompted bypass procedure that guides the operator through the sequence.
5. A step-wise pictorial & video presentation is provided on the touch-screen display during bypass.



eSTS Waits For The Perfect Moment To Transfer

The LayerZero eSTS eliminates downstream inrush by incorporating a patented “Dynamic Phase Compensation” algorithm that intelligently introduces an appropriate time delay at the instant of transfer. LayerZero provides an ITIC Plotting tool to audit the quality of transfers, to ensure that transfer times stay within the limits of ITIC curve parameters.

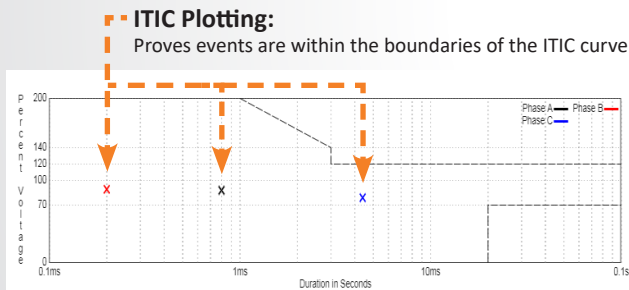

Real-Time Waveform Capture:

LayerZero Power Systems has integrated waveform capture functionality into all devices. Waveform capture automatically captures a picture of the power three-cycles before and after every event.

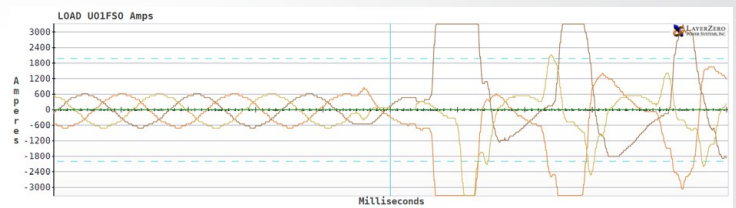

Without Dynamic Phase Compensation:

Excessive inrush current after the transfer

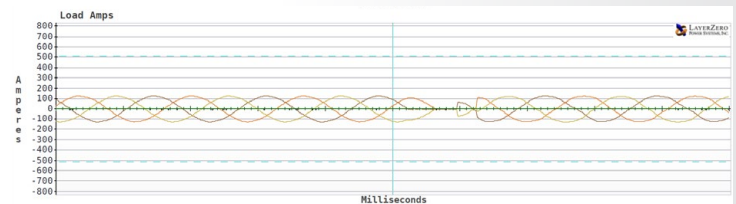

With Dynamic Phase Compensation:

Practically 0% inrush with transfer times within ITIC Curve parameters

Highly Connected Systems Designed for Direct Access to Information

INSIGHT IR® Provides Early Detection of Thermal Issues

INSIGHT IR® is an optional thermal monitoring system for LayerZero Power Systems products, designed to continuously monitor the temperatures of critical components. INSIGHT IR® captures data from a network of fixed infrared cameras and continuously looks for abnormal changes in thermal conditions. When a problematic connection is detected early, repairs can be made on equipment before the problem leads to downtime.

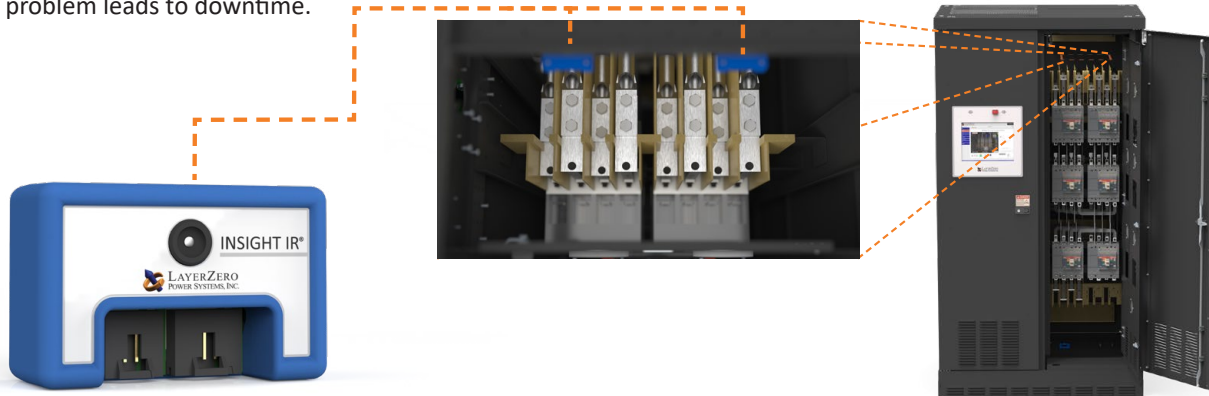

Information-Centric Connectivity

Every eSTS is equipped with an advanced Power Quality Monitoring (PQM) system equipped with local and remote communications options that are accessible utilizing non-proprietary protocols.

LayerZero eSTS Systems include basic monitoring, alarms, Waveform Capture, and ITIC Plotting capabilities. In addition, systems can be configured to automatically email users waveform captures as an attachment - so that if an event occurs, users do not have to look for the waveform capture image.



Waveforms Automatically Emailed:

LayerZero eSTS systems can be configured to automatically email users waveform captures as an attachment immediately after an event occurs.

Reliability Overview

eSTS is Designed and Tested for Seismic Compliance

eSTS Meet the Seismic Requirements of Critical Facilities Worldwide

The LayerZero eSTS is designed and tested to withstand seismic activity without becoming compromised. Products are seismic tested on a tri-axial shake table that provides independent motions of different magnitudes in 3 directions. The shake table testing proves how LayerZero equipment will actually respond in the event of an earthquake. Mere seismic paper studies are no substitute for a calibrated shake-table verification. Testing verifies that the mounting bolts remain seated, doors remain closed, mechanically locked critical components do not jam, and all of the controls are fully operational after a seismic event. LayerZero ensures product reliability in earthquake-prone locations by designing and testing equipment on an actual seismic shake table.

Compliance to the following AC-156 test criteria:

- Importance Factor, $I_p = 1.5$
Demand level
- Design spectral response acceleration at short period $S_{ds} = 2.0g$
- Height factor ratio $z/h = 1.0$

Horizontal

- $A_{flx-h} = 3.2g$
- $A_{rig-h} = 2.4g$

Vertical

- $A_{flx-v} = 1.34g$
- $A_{rig-v} = 0.54g$
- Seismic design category (SDC) = D

eSTS Has A Proven History of Reliability

LayerZero Power Systems has been designing and building Static Transfer Switches since 2001. The LayerZero eSTS is designed to be extremely reliable. LayerZero products are designed, fabricated, and tested in the same location. Our in-house development team has complete control over all processes that contribute to the quality aspects the manufacturing process - including the electrical designs, mechanical designs, and the software. As a result, LayerZero products are very high-quality and exceptionally reliable.



Optional Seismic Floor Stand

LayerZero SSQM Technical Specifications



SSQM Parameters		Mains
Voltage Inputs and Output	Voltage (Volts)	✓
	Voltage Average of Phases (Volts)	✓
	Frequency (Hertz)	✓
	Total Harmonic Distortion (Percent VTHD)	✓
	Phase Rotation	✓
Current Inputs	Current (Amps)	✓
	Current Average of Phases (Amps)	✓
	Current Imbalance (Percent)	✓
	Real Power (kilowatts)	✓
	Apparent Power (kilovolt-amperes)	✓
	Reactive Power (kilovolt-amperes reactive)	✓
	Power Factor	✓
	Crest Factor	✓
	Crest Factor Average of Phases	✓
	Phase Difference Between Sources	✓
	Phase Difference Between Sources and Output	✓
Alarms	Summary Alarm	✓
	On Source (1/2/3)	✓
	Source Fail (1/2/3)	✓
	Source Preferred (1/2/3)	✓
	Source 1st Alternate (1/2/3)	✓
	Source Over/Under Voltage (1/2/3)	✓
	Source Over/Under Frequency (1/2/3)	✓
	Source Not Available (1/2/3)	✓
	Output Failure	✓
	Source Overcurrent (1/2/3)	✓
	Source Exceeds Manual Limit (1/2/3)	✓
	Source Exceeds Automatic Limit (1/2/3)	✓
Bypassed to Source (1/2/3)	✓	

Technical Specifications: 3-Pole Static Transfer Switch

eSTS Models with Withstand Ratings				
eSTS Rating (100%)	120/208 V	480 V; 480/277 V; 415/240 V; 400/230 V; 220/380 V	600 V; 600/347 V; 575 V	
150 A	150kA; 100kA; 65kA	150kA; 100kA; 65kA; 35kA	100kA; 65kA; 35kA; 25kA	
250 A				
400 A				
600 A				
800 A	100kA; 65kA	100kA; 65kA; 50kA; 35kA	42kA; 35kA; 25kA	
1200 A		100kA*; 65kA; 50kA	65kA*; 50kA; 25kA	
* Upgrade to Automatic Circuit Breakers				
Mechanical Characteristics *				
	600 A	800 A	1000-1200 A	1600 A
Heat Dissipation	9,500 BTU/Hr	12,500 BTU/Hr	24,000 BTU/Hr	26,000 BTU / Hr
Weight	1,500 lbs (680 kg)	1,950 lbs (885 kg)	Please contact LayerZero Engineering	4,800 lbs (2177 kg)
Dimensions	48"W x 36"D x 80"H (1219 mm x 914 mm x 2032 mm)	58"W x 36"D x 80"H (1473 mm x 914 mm x 2032 mm)	96"W x 48"D x 90"H (2438 mm x 1219 mm x 2286 mm)	84.35"W x 42"D x 96"H (2142mm x 1066mm x 2438mm)
Frame Construction	Welded Frame			
Electrical Connections	Silver-Plated Solid Busbar			
Color	Textured Powder Coat White (RAL 7035), Blue (RAL 5017), Black, Custom			
Floor Stands	Optional			
Seismic floor stands	Optional			
Junction Boxes	Optional			
Sectionalization	Engineered Composite Insulation, Dead Front Doors			
Electrical Characteristics				
Number of Inputs	2, 3 (3 optional)			
Number of Output CBs	1, 2			
Frequency	50 Hz, 60 Hz			
Poles	3-pole			
Phases	3 Phase, 3 Wire, 4 Wire + Ground			
Neutral Rating	100%, 150%, 200%			
Transfer Time	Nominal 1/4- cycle for in-phase sources			
Redundancy	Single Module Redundancy, Triple Modular Redundancy (Optional)			
Circuit Breaker Type	Molded Case Switch (Standard), Electronic Trip (Optional)			
Circuit Breaker Mounting Type	Plug-In up through 600 A; Draw-out 800 A, 1200 A, 1600 A			
TVSS	Standard			
Power Quality Monitoring				
Power Quality Monitoring Technology	Zen SSQM™ (Static Switch Quality Monitoring)			
Waveform Capture	Local Display, Remote Display via Web Browser, Waveforms Automatically Emailed			
Voltmeter	Input sources and Output, for each phase			
Ammeter	Input sources and Output, for each phase			
Frequency Meter	Both Sources			
Synchroscope	Phase Angle Meter Between Sources			
Metering	Apparent Power, Real Power, Power Factor, Output Total Harmonic Distortion			
Time Stamped Transfer Count	From First Day Use, From Last Reset			
CB Status Indicator	Open/Closed/Tripped Circuit Breaker			
Source Indicator	Preferred Source			
Power Path Indicator	On Live Mimic			

*Dimensional & weight data is only valid for 2-source.

All product specifications are subject to change without notice.

Technical Specifications

Operational Characteristics	
Transfer Modes	Automatic; Manual (via Preferred Source Selection)
Inrush Mitigation Technology	Patented Dynamic Phase Compensation Algorithm (U.S. Patent 7,589,438 B2)
Cooling	Convection Cooling
Cable Access	Top/Bottom
Service Access	Front Only
Bypass Interlock Mechanism	Mechanical
Noise & Interference Isolation	Optical Fiber in Critical Control Paths
IR Scan Port Type	IR Portholes
IR Cameras (Optional)	Three (3) Fixed-Mount INSIGHT IR® Cameras
SCR Type	Puck
Display Type	15" Color Touch Screen
Display Resolution	1024x768
Bypass Assistance	Voice-Guided Bypass
Audio	Bezel-Mounted Stereo Speakers
Languages	English, French
Mimic Panel	Digital
Setpoints Control	Digital
Power Supplies	Redundant (4 Failure Groups. Triple Redundant Supplies. 12 Power Supplies Provided.)
Connectivity	
Meters	Local Display, Ethernet, Modbus/TCP, http via Web Browser (Non-Proprietary)
Alarms	Local Display, Ethernet, Modbus/TCP, http via Web Browser (Non-Proprietary)
Summary Alarm	Dry Contacts; Local Display; Modbus/TCP; Web Browser
Waveforms	Local Display, Ethernet, http via Web Browser (Non-Proprietary)
History/Event Log	Local Display, Ethernet, http via Web Browser (Non-Proprietary)
Diagnostics	Local Display, Ethernet, http via Web Browser (Non-Proprietary)
Time Synchronization	Network Time Protocol (NTP)
Standards Conformance	
CSA	ETL Listed to C22.22 No 107.
UL	ETL Listed to UL 1008S
Seismic	AC-156

All data tables above are for 3-pole only. Contact LayerZero for custom sizes and designs.

All product specifications are subject to change without notice.

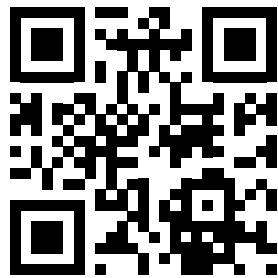

Learn more at www.LayerZero.com



LayerZero Power Systems, Inc.
1500 Danner Drive
Aurora, OH 44202 U.S.A.

© 2021 LayerZero Power Systems, Inc.

LayerZero Power Systems, LayerZero.com and the LayerZero logo are registered trademark of LayerZero.
All product specifications are subject to change without notice.

Rev. 4/21 #14